

DJI E1200 Pro

Propulsion Upgrade Kit For S900

User Manual

V1.0 2015.03

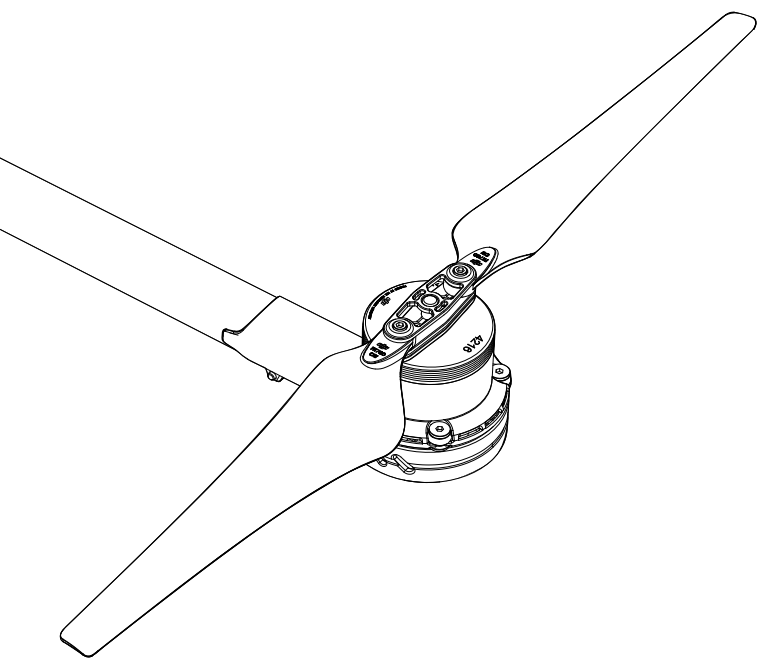

Disclaimer

Thank you for purchasing the E1200 Pro Propulsion Upgrade Kit for S900 (hereinafter referred to as “product”). Read this disclaimer carefully before using this product. By using this product, you hereby agree to this disclaimer and signify that you have read it fully. Please install and use this product in strict accordance with the manual. DJI assumes no liability for damage(s) or injuries incurred directly or indirectly from using, installing or refitting this product improperly, including but not limited to using accessories not designated.

This device complies with part 15 of the FCC Rules.

DJI is the registered trademark of SZ DJI Technology Co., Ltd. (abbreviated as “DJI”). Names of product, brand, etc., appearing in this manual are trademarks or registered trademarks of their respective owner companies. This product and manual are copyrighted by DJI with all rights reserved. No part of this product or manual shall be reproduced in any form without the prior written consent or authorization of DJI.

This disclaimer is made in various language versions; in the event of divergence among different versions, English version shall prevail.

Warnings

When powered on, the motors and propellers will rotate very quickly and may cause serious damage or injury. Always be vigilant and make safety your top priority.

1. Always fly your aircraft at a safe distance from people, animals, power lines, and other obstacles.
2. Do not get close to or touch the motors or propellers when the unit is powered on.
3. Before flying, ensure that the propellers and frame arms are installed correctly and that the propellers are unfolded.
4. Ensure that all ESC connectors and power cables connectors are securely attached before every flight.
5. Ensure that all dampers are in good condition before every flight. If they are not, they may adversely affect flight performance and should be replaced prior to flight.
6. Check to ensure that all parts of the aircraft are in good condition before flight. Do not fly with worn or damaged parts.
7. Only use compatible DJI parts.

Legend

 Important

 Hints and Tips

If you encounter any problems or if you have any questions, please contact your local DJI authorized dealer or DJI Support.

DJI Support Website:
www.dji.com/support



About

The E1200 Pro Propulsion Upgrade Kit for S900 is designed for use with DJI S900 multirotor flying platforms. The E1200 Pro features enhanced efficiency, security, and endurance. The Z-Blade 17-inch foldable propellers are made using an advanced carbon-fiber-reinforced polymer, which reduces rotational inertia and enhances rigidity. New, upgraded motors promote efficient heat dissipation to improve endurance and reliability, even when flying in harsh environments. The Smart ESCs feature a sinusoidal drive, which provides greater efficiency and more agile dynamic response. After upgrading with this kit, your S900 will feature enhanced flight endurance, increased maximum takeoff weight, higher maximum takeoff altitude, and an extended range of environmental working temperatures.

1. In the Box

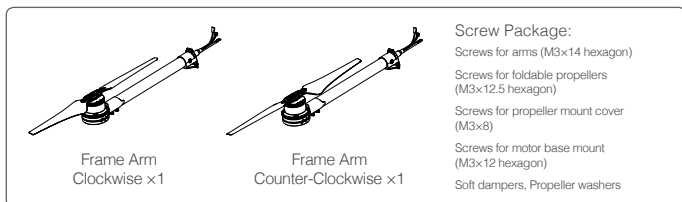

2. Gain Value Settings

The new E1200 Pro ESC, features a sinusoidal drive, which replaces the traditional square wave drive to offer improved performance when accelerating and decelerating. To achieve the same sensitivity as older ESCs, which use a traditional square wave drive, reduce the gain values according to your flight control system and frame. The table below shows typical gain values when using the E1200 Pro and a DJI A2 flight control system on a platform with a takeoff weight of 8 kg:

Basic			Attitude		
Pitch	Roll	Yaw	Pitch	Roll	Vertical
110%	110%	55%	160%	160%	85%

3. Installation

Tools compatible with the following screws are required:

Screws (M4x35), Screws for upper plate (M2.5x8 cheese head), Screws for round cover (M3x8 self-tapping), Screws for power cable bracket (M3x5.5 square drive, hexagon)

1) Remove the original frame arms of the S900

- If the frame arm is erect, twist the red knob at the arm junction and lower the frame arm.

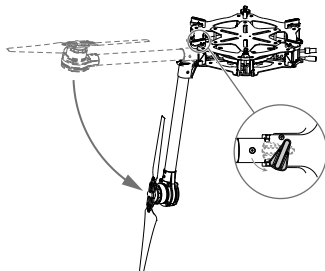

- b. Now unscrew the six screws (M2.5×8 cheese head) on the upper plate of the center frame and remove the upper plate. Then unscrew the four screws (M3×8 self-tapping) that secure the round cover and remove it.
- c. Disconnect each ESC signal cable from the center frame. Then remove each screw (M3×5.5 square drive, hexagon) on the connecting bracket and unplug the power cables.

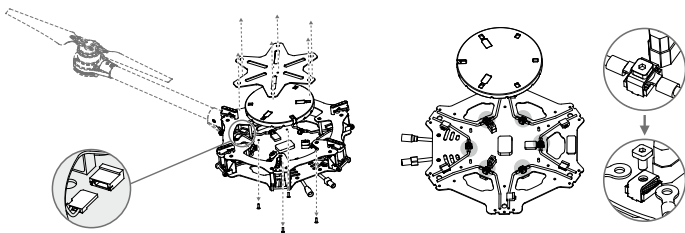

- d. Unscrew the M4×35 screw and remove the original frame arm.

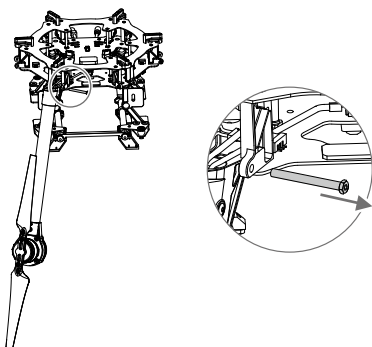

2) Install the upgrade frame arms

- a. Prepare the arms by:

Checking all propellers for cracks and ensuring that all screws are tightened,
 Ensuring that all motors are mounted firmly and rotate freely,
 Identifying the clockwise and counter-clockwise marks on the propellers. The arms with the counter-clockwise marks will be mounted at positions M1, M3 and M5 of the center frame. The arms with the clockwise marks will be mounted at positions M2, M4 and M6 of the center frame.

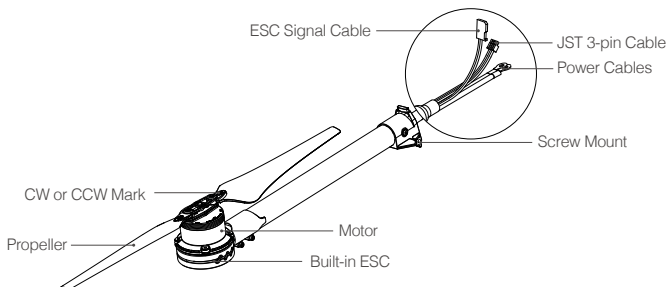

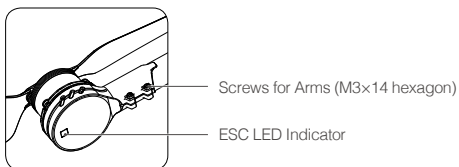

- b. Insert the frame arm into the mounting slot on the center frame and line up the screw holes of the frame arm and center frame.
- c. Insert the M4x35 screw from the right side of the frame arm, as shown below. Tighten each screw securely, but avoid over-tightening, which may lead to connector abrasion.

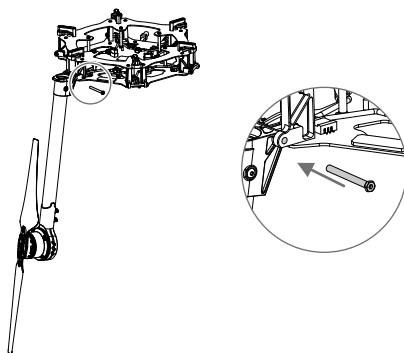

- d. Gently lift the frame arm and twist the red knob to lock the arm in place.

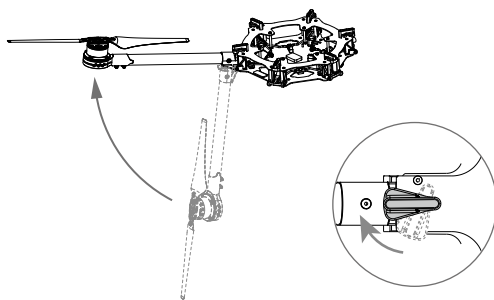

- e. Plug each ESC signal cable into the slot nearest to each arm on the center frame.

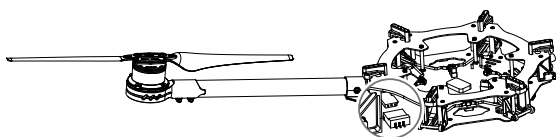

- f. Connect the power cables to the center frame. Red cables correspond with the positive terminals and black cables correspond with the negative terminals. Rotate the bracket screws until they are tight and properly aligned with the connecting brackets, as shown below.

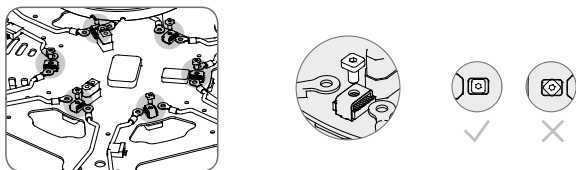

- g. Tuck the excess length of the JST 3-pin cable back into the frame arm to avoid any potential flight complications.
h. Ensure that all ESC signal cables and power cables are correctly connected onto the center frame.

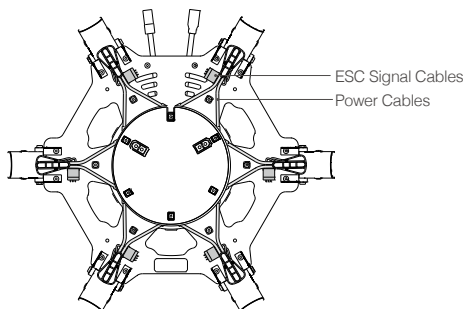

- i. Replace the round cover and tighten the four screws (M3x8 self-tapping), then replace the upper plate of the center frame and tighten the six screws (M2.5x8 cheese head).

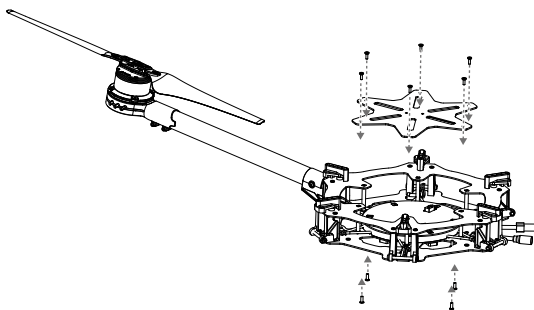

- j. Double check all frame arms. Arms M1 and M2 correspond with the nose direction of the aircraft. Arms M4 and M5 correspond with the tail. When viewed from above, the motors on arms M1, M3 and M5 should rotate counter clockwise and the motors those on arms M2, M4 and M6 should rotate clockwise.

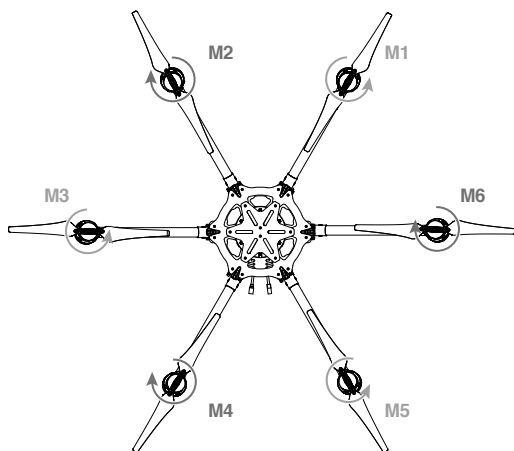

4. Using the DJI ESC Assistant

The DJI ESC Assistant is used to upgrade ESC firmware, configure the propulsion system, etc.



- An Updater is required and is not included with the E1200 Pro. To use the DJI ESC Assistant, connect the integrated ESC to a computer through the Updater, as shown below.
- Download the ESC Assistant:
<http://www.dji.com/product/e1200/download>

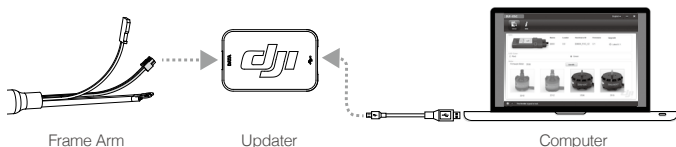









Before using the Updater, unplug any other serial devices that are connected to your computer, then follow the instructions below:

- 1) Download the ESC Assistant from the DJI website. Run the installer and follow the prompts to complete the installation process.
- 2) Plug the JST 3-pin cable of the frame arm into the data port of the Updater and use a Micro-USB cable to connect the other end of the Updater to a computer. Turn on the ESC system by connecting it to a 6S LiPo battery and do not disconnect the integrated ESC from the computer until the configuration is complete.
- 3) Run the ESC Assistant software and wait for the ESC to connect to the program. Watch the indicators on the bottom of the screen. When the ESC has been successfully connected, the "Computer Connection" status will be solid green and the Data Exchange Indicator will blink blue.

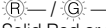
- 4) Click on the "View" tab. In the "ESC" section, check the current firmware version and ensure that the installed firmware up-to-date. If it is not, click the link and follow the prompts to update it.

 If the ESC is not automatically recognized by the DJI ESC Assistant (the indicators on the bottom of the screen show a solid green and an inactive blue), check whether there is more than one DJI Updater, FTDI USB adapter, or other developer tool (including, but not limited to, BeagleBone, Raspberry, Arduino, etc.), which may use the FTDI chipset, connected to the computer. If any of these FTDI devices are connected, simply unplug them and keep the DJI Updater connected to the computer. Then, restart the DJI ESC Assistant and the ESC system to form a successful connection.

5. ESC LED Indicator & Sound Description

LED Indicators	Sound	Description
 Yellow-Green, blinking in turn	None	Motor is being connected
 /  Red or Green, blinking slowly	♪1356	Ready
 — /  — Solid Red or Green	None	Motor starts normally
 Red-Yellow, blinking in turn	None	Self-test failure
	BB---BB---BB... BBB---BBB...	Input voltage is abnormal The motor parameters don't match the firmware data saved in the ESC
 Yellow, blinking quickly	BBBBBB...	Throttle stick is not at the bottom position
 Yellow, blinking slowly	B-----B-----B...	No signal input
 — Solid Yellow	None	Motors are rotating at full throttle
Red, blinking quickly	None	Error, land your aircraft immediately*

* You can learn more about an error by connecting the integrated ESC to the ESC Assistant.

 You can interpret the working status of the unit by observing the LEDs and listening to the sounds emitted from the ESC.

6. Specifications

Max Thrust	3900 g/rotor @ 25 V (Sea Level)
Takeoff Weight Recommended	1200 to 1400 g/rotor (Sea Level)
Battery Recommended	6S LiPo

Frame Arm Weight (Single)	385 g
Cable Length	460 mm
Working Temperature	-10 to 60°C
Arm Tube	
Length	290 mm
Outer Diameter	25 mm
Wall Thickness	1 mm
ESC	
Max Allowable Voltage	26 V
Max Allowable Current (Persistent)	40 A
Signal Frequency	30 to 450 Hz
Battery	6S LiPo
Motor	
Stator Size	42×16 mm
KV	310 rpm/V
Weight	205 g
Propeller	
Diameter / Thread Pitch	17×6.0 inch

Motor Dimensions

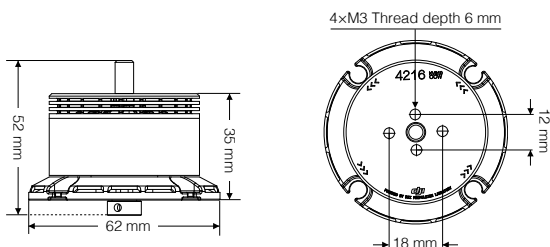

7. Comparison of the S900 Specifications

Specifications	Before Upgrading	After Upgrading
Frame		
Diagonal Wheelbase	900 mm	920 mm
Frame Arm Length	358 mm	368 mm
Frame Arm Weight (with Motor, ESC, Propeller)	316 g	385 g
Motor		
Stator Size	41×14 mm	42×16 mm
KV	400 rpm/V	310 rpm/V
Max Power	500 W	700 W

Weight (with Cooling Fan)	158 g	205 g
Foldable Propeller		
Size	15x5.2 inch	17x6.0 inch
Weight	13 g	23 g
Flight Parameters		
Takeoff Weight	4.7 to 8.2 kg	4.7 to 10 kg
Total Weight	3.3 kg	3.7 kg
Max Power Consumption	3000 W	4000 W
Hovering Power Consumption	1000 W (@ 6.8 kg Takeoff Weight)	770 W (@ 6.8 kg Takeoff Weight)
Hovering Time	18 min (@ 12000 mAh with a 6.8 kg Takeoff Weight)	23 min (@ 12000 mAh with a 6.8 kg Takeoff Weight)
Working Temperature	- 10 to 40 °C	- 10 to 60 °C

8. FAQ

Remounting the Propellers

- 1) Use the two foldable propeller mounting screws (M3×12.5 hexagon), the two propeller cover mounting screws (M3×8), and the four propeller washers to remount the propellers.
- 2) First apply thread locker to the thread of the propeller mount, then tighten the screws until the propeller blades are securely clamped and can rotate freely.



Loose screws cannot be securely locked in place with thread locker.

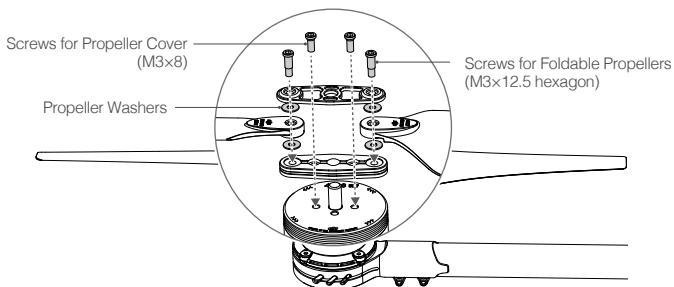

Propeller Precautions

Check the markers on the screws and propeller covers before every flight. If the propellers are loose, the markers will provide a visual cue, indicating that the screws should be tightened.

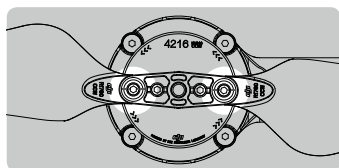
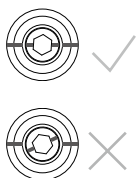

Assembling Motor Vibration Absorbers

Affix the motor vibration dampers, as shown below. First insert the dampers, then tighten the four screws (M3×12 hexagon) on motor base mount. The assembly process is identical for both the clockwise and counter-clockwise propellers.

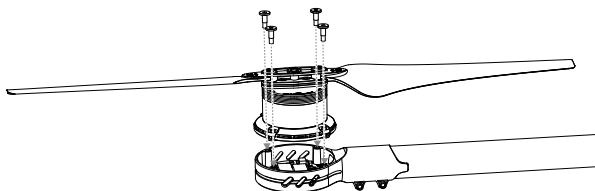
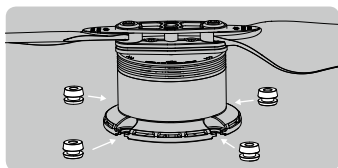

Ensure that all dampers are in good condition before every flight. If they are not, they may adversely affect flight performance and should be replaced immediately.

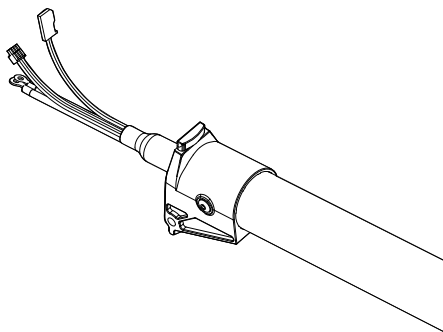

The content is subject to change.

Download the latest version from
<http://www.dji.com/product/e1200>



If you have any questions about this document, please contact DJI by sending a message to DocSupport@dji.com.

© 2015 DJI. All Rights Reserved.